

STARLINE Series

MB120

1.2 GHz Mini-Bridger Amplifier

FEATURES

- Supports 1.2 GHz Downstream and 204 MHz Upstream bandpass for DOCSIS® 3.1 migration
- Modular RF Electronics package with upgradable frequency split options
- Increased gain to allow drop in upgrades for ≥ 750 MHz spacing
- Mechanically compatible with legacy Mini-Bridger housings
- Expand return path bandwidth with support up to 204 MHz
- QAM ADU options for automatic level control and gain hold in the event of pilot loss



PRODUCT OVERVIEW

For cable operators looking to ensure maximum backward compatibility, scalability, and protect network investments, ARRIS offers solutions that deliver new services with minimal CAPEX, enhance network efficiency, and increase subscriber satisfaction.

The new ARRIS 1.2 GHz MB120 Mini-Bridger Amplifier enables cable operators to take advantage of DOCSIS 3.1 efficiencies while maintaining backward compatibility of existing 750 MHz, 870 MHz, and 1 GHz systems.



Downstream

The new MB120 amplifier is equipped with Gallium Nitride (GaN) technology with two driven RF outputs. A plug-in jumper now allows port 2 to be enabled/disabled as required for network designs. Port 3 can also be enabled with the optional Splitter or Direction Coupler plug-ins. New 1.2 GHz Forward Cable Equalizers (CE-120-*) and Cable Simulators (CS-120-*) are available to optimize system designs. These new plug-ins are in the JXP-style form factor and plug into a carrier board with a backward compatible footprint so that operators who want to use the new amplifiers in older 870 MHz or 1 GHz systems can re-use their standard accessories. The MB120 utilizes pluggable diplex filters, which provides operators the flexibility to change band splits in the future.

The following frequency splits are available:

- 5 to 42 MHz/54 to 1218 MHz (042 split)
- 5 to 65 MHz/85 to 1218 MHz (065 split)
- 5 to 85 MHz/102 to 1218 MHz (085 split)
- 5 to 204 MHz/258 to 1218 MHz (204 split)

Upstream

The MB120 can be ordered with either 20 dB or 24 dB of gain in the upstream, depending on network requirements. There is an attenuator location prior to the input test points, as well as one following the output test point, that allows operators to achieve the desired levels. The return path equalizer maintains the SRE-* form factor from the MB100, and operators can select SRE return path equalizers ranging from 0 to 10 dB in 2 dB increments based on their network design.

Backward Compatibility

The MB120 RF electronics package is backward compatible with the MB87 and MB100 amplifier housings. MB-750 and MB86 housings were rated at 10 Amps and will require the installation of the MB-15All Kit, which allows for the amplifier to carry 15 Amperes continuous through its input or output ports.

COMPATIBILITY

Platform	MB-550	MB-750D	MB-750SH	MB86	MB87	MB100
Upgrade to MB120	No	No	Yes*	Yes*	Yes	Yes

* Requires MB-15All Kit

SPECIFICATIONS

Downstream Parameter		Units	Specification
Frequency split ¹	042 Split	MHz	54–1218
	065 Split		85–1218
	085 Split		102–1218
	204 Split		258–1218
Flatness ²		dB	± 0.75
Operational Gain ³		dB	47
Internal Slope ⁴	042 Split	dB	16.1
	065 Split		15.2
	085 Split		14.7
	204 Split		11.5
Noise Figure ⁵		dB	8
Test Points		dB	20 ± 1.0
Return Loss		dB	16
Hum Modulation @ 15A ⁶	F _{minfwd} to 1003 MHz	dBc	< 60
	1003 MHz to 1218 MHz	dBc	< 50
Distortion: 1.2 GHz Analog/Digital, 30 Analog, 160 Digital Channels ⁷			
Reference Frequency		MHz	1218/258/54
Reference Input Level		dBmV	8/5.5/7.1 (virtual)
Reference Output Level (17 dB Slope)		dBmV	55/41/38 (virtual)
Composite Triple Beat (CTB) ⁸		dBc	74
Composite Second Order (CSO) ⁸		dBc	78
Carrier to Composite Noise (CCN)		dB	56
Distortion: 1.2 GHz All Digital, 190 Digital Channels ⁷			
Reference Frequency		MHz	1218/550/54
Reference Input Level		dBmV	2/-0.6/1.1 (actual)
Reference Output Level (17 dB Slope)		dBmV	49/39.2/32 (actual)
CCN ⁸		dB	49
BER ⁸		dB	< 1x10 ⁻⁶

NOTES:

- Operating passband of station, determined by the diplex filters, forward correction board and high pass filter installed in the amplifier.
- Flatness is measured with respect to slope. Slope is calculated using best fit.
- Includes the gain control back off of 4.9 ± 0.1 dB and forward equalizer loss.
- Calculated for 19.7 dB of cable loss at 1218 MHz. Internal slope with 0 dB EQ installed.
- Measured at 1218 MHz. Specified at the housing cable entry facility over temperature and includes the loss of 1 dB for the equalizer.
- Hum modulation is measured at 15 Arms AC current passing through the port under test.
- The QAM load is 256 QAM, J.83 Annex B, 5.360537 MS/s; 6 MHz/channel.
- Output level is 49 dBmV (actual) at 1218 MHz with 17 dB tilt from 54 MHz to 1218 MHz. CCN is measured by turning off the QAM channel under test and inserting a CW test signal at the corresponding QAM RF level in its place.

SPECIFICATIONS

Upstream Parameter		Units	Specification
Frequency split ¹	042 Split	MHz	5–42
	065 Split		5–65
	085 Split		5–85
	204 Split		5–204
Flatness ²		dB	± 0.5
Operational Gain		dB	20 or 24 (according to gain option selected)
Reference Operating Slope		dB	± 0.75
Noise Figure (20 dB Gain Option)		dB	9
Noise Figure (24 dB Gain Option)		dB	8
Test Points		dB	20 ± 1.0
Return Loss		dB	16
Hum Modulation @ 15A ³		dBc	< 60
Distortion: All Digital, 6 Digital Channels ⁶			
Reference Frequency		MHz	42/5
Reference Input Level (20 dB Gain Option)		dBmV	16/16
Reference Input Level (24 dB Gain Option)		dBmV	12/12
Reference Output Level (0 dB Slope, 20 dB Gain Option)		dBmV	36/36
NPR Dynamic Range ⁴		dB	36
BER Dynamic Range ⁵		dB	42
Reference Output Level (0 dB Slope, 24 dB Gain Option)		dBmV	36/36
NPR Dynamic Range ⁴		dB	32
BER Dynamic Range ⁵		dB	38
Distortion: All Digital, 13 Digital Channels ⁶			
Reference Frequency		MHz	85/5
Reference Input Level (20 dB Gain Option)		dBmV	12/12
Reference Input Level (24 dB Gain Option)		dBmV	8/8
Reference Output Level (20 dB Gain Option)		dBmV	32/32
NPR Dynamic Range ⁴		dB	33
BER Dynamic Range ⁵		dB	39
Reference Output Level (0 dB Slope, 24 dB Gain Option)		dBmV	32/32
NPR Dynamic Range ⁴		dB	29
BER Dynamic Range ⁵		dB	35

NOTES:

1. Operating passband of station, determined by the diplex filters, Return Path Low Pass Filter and Return Equalizer installed in the amplifier.
2. Flatness is measured with respect to slope.
3. Hum modulation is specified from 10 MHz to F_{maxret} and is measured with 15 Arms AC current passing through the port under test.
4. The NPR dynamic range is specified for an NPR greater than or equal to 40 dB.
5. The BER dynamic range is specified for an uncorrected (Pre-FEC) BER less than or equal to 1.0×10^{-6} .
6. The QAM load is 256 QAM, J.83 Annex B, 5.360537 MS/s; 6 MHz/channel.

SPECIFICATIONS

Upstream Parameter (cont.)	Units	Specification
Distortion: All Digital, 33 Digital Channels ¹		
Reference Frequency	MHz	204/5
Reference Input Level (20 dB Gain Option)	dBmV	9/9
Reference Input Level (24 dB Gain Option)	dBmV	5/5
Reference Output Level (0 dB Slope, 20 dB Gain Option)	dBmV	29/29
NPR Dynamic Range ²	dB	29
BER Dynamic Range ³	dB	34
Reference Output Level (0 dB Slope, 24 dB Gain Option)	dBmV	29/29
NPR Dynamic Range ²	dB	25
BER Dynamic Range ³	dB	30
Powering Specifications	Units	Specification
AC Input Current (typical)	@ 44 V @ 60 V @ 90 V	1.0 A/40.8 W 0.71 A/39.6 W 0.47 A/38.8 W
DC Voltage	VDC	24
Current DC Max	mA	1.5
AC Input Voltage Range	VAC	38–90
AC Bypass Current (all ports)	A	15
General Specifications	Units	Specification
Operating Temperature Range	C F	–40° to +60° –40° to +140°
Housing dimensions, L x W x D	inches mm	15.4 x 9.6 x 5.5 292 x 244 x 140
Weight	lb kg	15 6.8

NOTES:

1. The QAM load is 256 QAM, J.83 Annex B, 5.360537 MS/s; 6 MHz/channel.
2. The NPR dynamic range is specified for an NPR greater than or equal to 40 dB.
3. The BER dynamic range is specified for an uncorrected (Pre-FEC) BER less than or equal to 1.0×10^{-6} .

RELATED PRODUCTS

ADU/QADU	SRE Return Equalizers
BLE120	Installation Services
CE-120* Forward Cable Equalizers	CS-120* Forward Cable Simulators

1.2 GHz MB ORDERING GUIDE

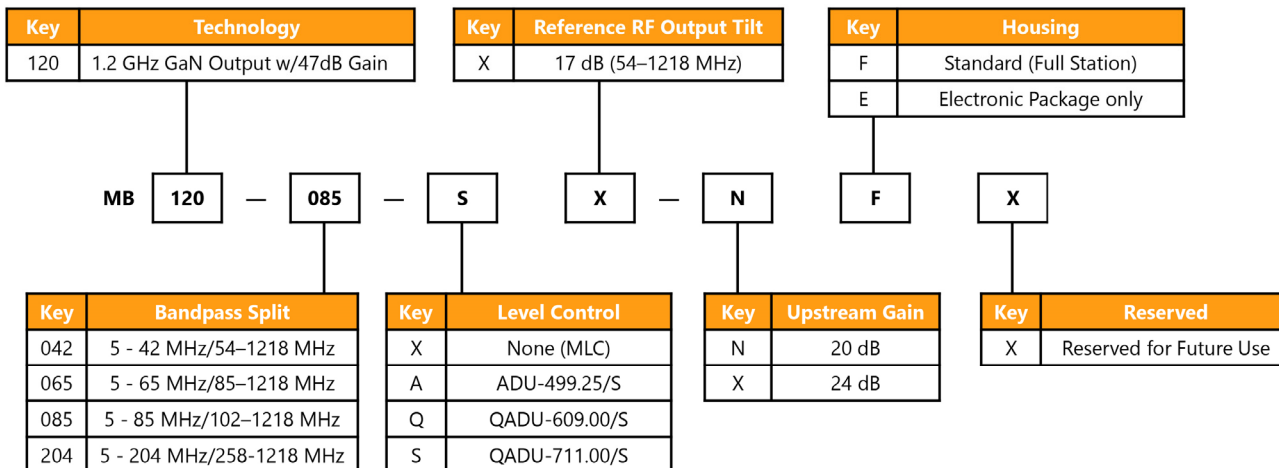

NOTE:

1. FTEC and 30A fuses are included in all models as standard.

REQUIRED ACCESSORIES

Model Name	Description
CE-120-*	Forward 1218 MHz Cable Equalizer 1 to 20 dB in 1 dB steps -or-
CS-120-*	Forward 1218 MHz Cable Simulator 1 to 10 dB in 1 dB steps
SRE-**-*	Return Equalizer, 5–42 MHz (042 Split), 5–65 (065 Split), 5–85 (085 Split), 5–204 (204 Split), values 0 to 10 dB in 2 dB steps
NPB-*	Plug-in attenuator/pad (values 0 to 26 dB in 1 dB steps)

OPTIONAL ACCESSORIES

Model Name	Description
SP100	Splitter to activate Port 3
DC100/8	Directional coupler (8 dB) to activate Port 3
DC100/10	Directional coupler (10 dB) to activate Port 3
DC100/12	Directional coupler (12 dB) to activate Port 3
MB-15AII-KIT	15 Amp platform kit to upgrade older 10 Amp housings

Customer Care

Contact Customer Care for product information and sales:

- United States: 866-36-ARRIS
- International: +1-678-473-5656

Note: Specifications are subject to change without notice.

Copyright Statement: © 2020 CommScope, Inc. All rights reserved. ARRIS and the ARRIS logo are trademarks of CommScope, Inc. and/or its affiliates. All other trademarks are the property of their respective owners. No part of this content may be reproduced in any form or by any means or used to make any derivative work (such as translation, transformation, or adaptation) without written permission from CommScope, Inc and/or its affiliates (“CommScope”). CommScope reserves the right to revise or change this content from time to time without obligation on the part of CommScope to provide notification of such revision or change